

- i**
- MICRO
- TITAN
- TPH
- TPS
- TPSP
- TPF
- TPK
- TPC
- TPR
- TPB
- TPHC
- TPA
- TPG
- TPCT
- TPSL**
- STOP CYLINDER
- STOP CYLINDER
- TPSR
- TPSRs
- TPNS
- TPHT
-
-
-
-
-
-
-
-

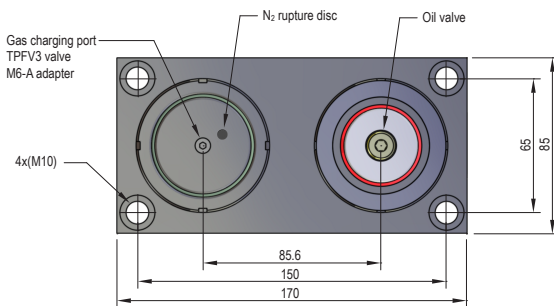
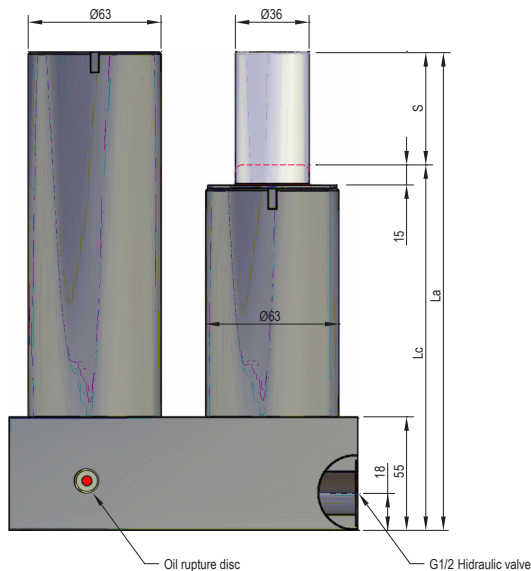

Code	Smax mm	La mm	Lc mm	Max. operation force	Charging N ₂ pressure		Max. working specifications		Max. working temperature
					Min.	Max.	Velocity	Strokes / min	
TPCH 3000x25	25	183	158	3000 daN	50 Bar	150 Bar	20 m/min	40 spm	60 °C
TPCH 3000x50	50	233	183					30 spm	
TPCH 3000x80	80	293	213					20 spm	